

CV EXPLOSION VENT

DESCRIPTION

Fike designs simple, reliable explosion protection solutions to meet your safety requirements. Fike's Composite Vent, or CV, is the most widely used explosion vent, and sets the industry standard. This flat vent layers stainless steel and Teflon® to create a high performance explosion vent which provides excellent service life for static to light pressure cycling conditions and light vacuum conditions. Typical applications include separation, drying, storage, conveyance, and processing operations.

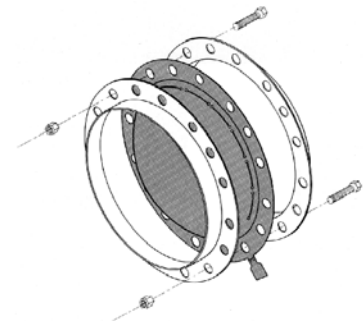

Typical Explosion Vent
And Mounting Frame

FIKE SERVICES

Fike expertise creates the right explosion protection solution for your specific application:

- Engineers and application specialists familiar with your application and applicable codes
- **Rapid Response** - lower costs and lead times with Fike's exclusive stock program shipping the most popular sizes and burst pressures in 2 days
- Product testing and hazard analysis
- Vent relief area sizing software online at www.Fike.com (NFPA/European standards)

STANDARD FEATURES

Instantaneous Full Opening

Fail-Safe Design

Dynamically Tested - Fike exclusive!

100% Venting Efficiency

High Mechanical Integrity

Easy Installation by Plant Personnel

Non-Fragmenting Design

Maintenance Free

BENEFITS

Reduced risk for accidental contamination, elimination of undetected openings

Certified burst pressure provides full, predictable opening at or below its rated burst pressure even if the vent is damaged

Tested under full-scale explosion conditions not just computer modeling

Optimal relief area

Longer service life

Reduced downtime and maintenance costs

Reduced risk to personnel and equipment

Reduced cost of ownership

SPECIFICATIONS

Compliance:

Atex Certified / NFPA 68

Materials of Construction:

316 SST / Teflon® / 316 SST

Maximum Operating Pressure/Vacuum Rating:

75% of the minimum stamped burst pressure for BP ≤ 1.5 psig

60% of the minimum stamped burst pressure for BP > 1.5 psig

Standard Burst Pressure Tolerance:

± 0.25 psig for burst pressures < 1.0 psig

± 0.5 psig for burst pressures 1.0 - 4.0 psig

± 1.0 psig for burst pressures > 4.0 psig

Operating Temperature Range:

-40° C up to 260° C / -40°F up to 500°F

Optional Equipment:

Burst Indicators / Monitoring System

Atmospheric Insulation

Process Insulation

Weather Covers

Installation Frame

Flameless Venting

Alternative materials, temperature ranges, and tighter tolerances are available

Form No. X.1.14.01-1

Vent Size		Relief Area		Minimum Burst Pressure		Maximum Burst Pressure	
in.	cm	ft ²	m ²	psig	mbarg	psig	mbarg
9 x 12	23 x 30	0.61	.057	2.0	138	10.0	690
12 x 12	30 x 30	0.84	.078	2.0	138	8.0	550
12 x 18	30 x 46	1.30	.12	1.5	103	8.0	550
*12 x 24	30 x 61	1.76	.16	1.5	103	8.0	550
18 x 18	46 x 46	2.01	.19	1.0	69	8.0	550
18 x 24	46 x 61	2.72	.25	1.0	69	8.0	550
18 x 30	46 x 76	3.42	.31	1.0	69	8.0	550
24 x 24	61 x 61	3.67	.34	1.0	69	8.0	550
20 x 30	51 x 76	3.83	.36	1	69	8.0	550
*18 x 35	46 x 89	4.01	.37	1.0	69	8.0	550
18 x 36	46 x 91	4.13	.38	1.0	69	8.0	550
24 x 30	61 x 76	4.63	.43	1.0	69	8.0	550
*24 x 36	61 x 91	5.59	.52	.5	35	8.0	550
30 x 30	76 x 76	5.84	.54	.5	35	8.0	550
24 x 44	61 x 112	6.87	.64	.5	35	8.0	550
30 x 36	76 x 91	7.05	.66	.5	35	8.0	550
24 x 48	61 x 122	7.51	.7	.5	35	8.0	550
36 x 36	91 x 91	8.51	.79	.5	35	8.0	550
30 x 44	76 x 112	8.66	.81	.5	35	8.0	550
*36 x 44	91 x 112	10.45	.97	.5	35	8.0	550
44 x 44	112 x 112	12.84	1.19	.5	35	8.0	550
44 x 69	142 x 175	20.31	1.89	.5	35	8.0	550
6 Dia.	15 Dia.	.14	.013	3.0	207	15.0	1030
8 Dia.	20 Dia.	.28	.026	2.5	172	15.0	1030
10 Dia.	25 Dia.	.45	.042	2.0	138	11.0	760
12 Dia.	30 Dia.	.68	.063	2.0	138	10.0	690
14 Dia.	36 Dia.	.95	.088	1.5	103	10.0	690
16 Dia.	41 Dia.	1.27	.12	1.25	86	10.0	690
18 Dia.	46 Dia.	1.62	.15	1.0	69	10.0	690
20 Dia.	51 Dia.	2.02	.19	1.0	69	10.0	690
22 Dia.	56 Dia.	2.46	.23	1.0	69	10.0	690
24 Dia.	61 Dia.	2.95	.27	1.0	69	10.0	690
26 Dia.	66 Dia.	3.48	.32	.8	69	10.0	690
30 Dia.	76 Dia.	4.67	.43	.5	35	10.0	690
36 Dia.	91 Dia.	6.78	.63	.5	35	10.0	690
40 Dia.	102 Dia.	8.40	.78	.5	35	10.0	690
44 Dia.	112 Dia.	10.20	.95	.5	35	10.0	690

- * These sizes are stocked at the factory for 1.5 psig nominal burst pressure 72° only
- Custom sizes are available
- All dimensions are nominal

INSTALLATION

CV rectangular and circular vents can be mounted in several lightweight angle frame configurations. CV circular explosion vents can also be installed between standard weld neck flanges in accordance with DIN 3632 PN10 or ANSI B16.5 150. Fike offers frames of multiple configurations and materials. If you prefer to make your own frames, drawings can be purchased

